

DATA SHEET

Magnet FilterBall – ball valve w. strainer & magnet

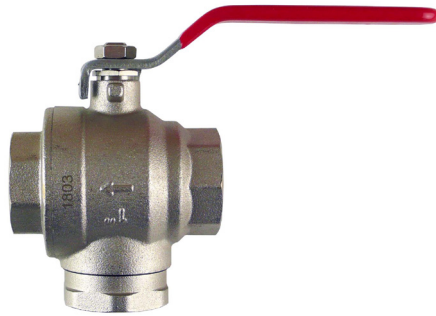

code 17404, 17405, 17406, 17407, 17408

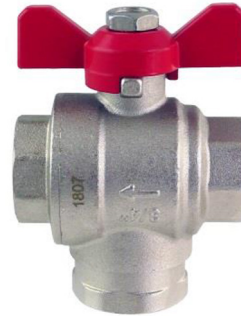

code 18318, 18319, 20256

Main Features

Application	Intended for tight closure or opening of working fluid flow and impurities filtering.
Description	Ball valve with integrated strainer + magnet.
Control	Manual opening/closing.
Working fluid	Drinking water, water, antifreeze fluid for heating systems, heat pumps and solar thermal systems.
Maintenance	For strainer cleaning, close the ball valve completely, unscrew the lid with magnet and remove the strainer.
Installation	Horizontal or vertical, always respect the flow direction marked by an arrow on the housing; for proper functioning the valve shall be fully open during operation and fully closed during maintenance and strainer cleaning.

Name	Code	Connection size
3/4" F Magnet FilterBall – lever	17404	G 3/4" F
3/4" F Magnet FilterBall – butterfly	18318	G 3/4" F
1" F Magnet FilterBall – lever	17405	G 1" F
1" F Magnet FilterBall – butterfly	18319	G 1" F
5/4" F Magnet FilterBall – lever	17406	G 5/4" F
5/4" F Magnet FilterBall – butterfly	20256	G 5/4" F
6/4" F Magnet FilterBall – lever	17407	G 6/4" F
2" F Magnet FilterBall – lever	17408	G 2" F

Composition of the ball valve w. strainer & magnet

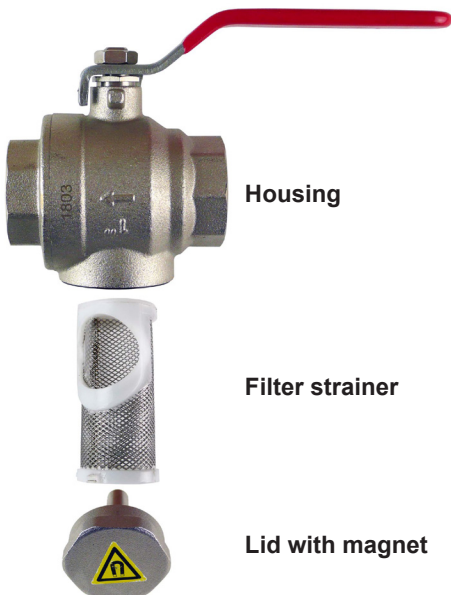

Housing

Filter strainer

Lid with magnet

Technical Data

Max. working pressure	16 bar
Max. working temperature	-20 °C to 100 °C
Magnetic induction	7 000 Gs
Filter mesh size	0.6 mm

Materials

Valve housing	nickel-plated brass
Lid	nickel-plated brass
Magnet	neodymium NdFeB
Filter strainer	stainless steel
O-ring (lid)	EPDM
Lid gasket	EPDM
Closing ball	chrome-plated brass
Ball seal	PTFE
Spindle	brass
Spindle seal	PTFE
Packing nut	brass
Lever / butterfly	steel

DATA SHEET

Magnet FilterBall – ball valve w. strainer & magnet

Dimensions

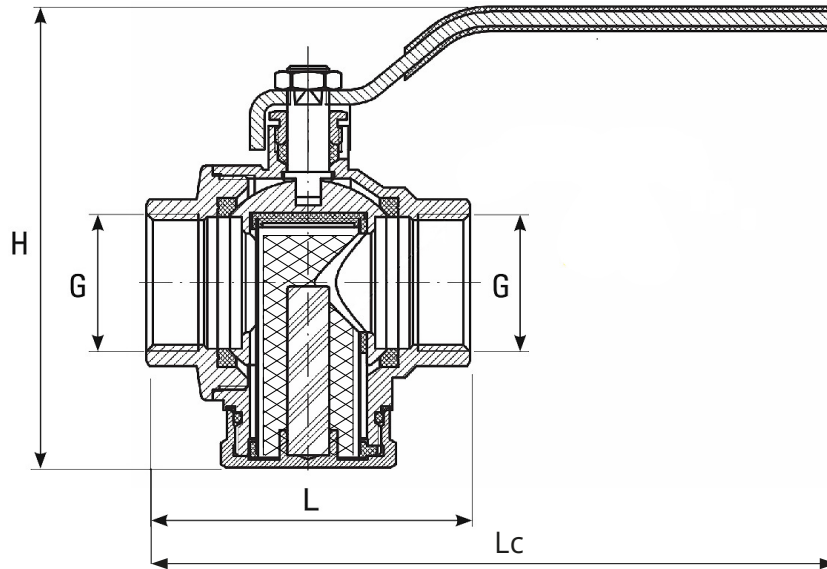

Code	Dimensions				DN [mm]	Kvs [m ³ /h]	Weight [kg]
	G	Lc [mm]	L [mm]	H [mm]			
17404	3/4" F	140	65	100	20	7.8	0.6
18318	3/4" F	140	65	95	20	7.8	0.5
17405	1" F	146	78	106	25	10.2	0.8
18319	1" F	146	78	103	25	10.2	0.8
17406	5/4" F	182	87	129	32	19.0	1.3
20256	5/4" F	182	87	122	32	19.0	1.3
17407	6/4" F	192	108	144	40	26.5	2.0
17408	2" F	310	127	188	50	43.1	3.9

Pressure drop diagram for 17404, 17405, 18318, 18319

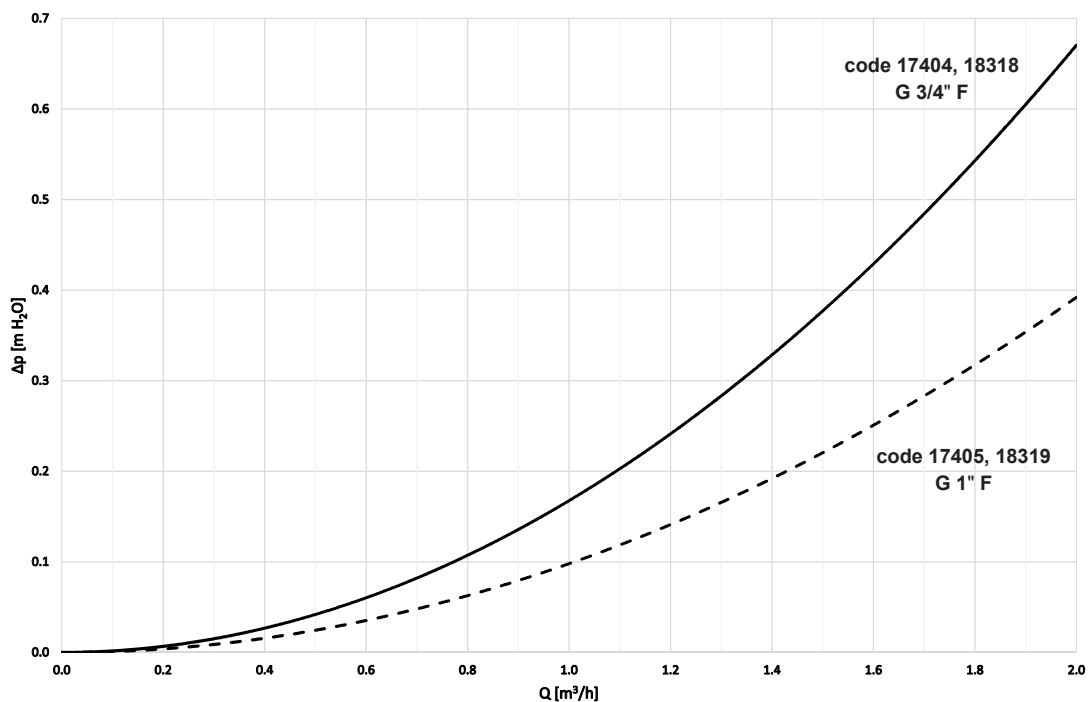

DATA SHEET

Magnet FilterBall – ball valve w. strainer & magnet

Pressure drop diagram for 17406, 17407, 17408, 20256

